

## Seoul Semiconductor is the Technology Leader in LED Innovation

Seoul Semiconductor is one of the top two independent (non-captive) LED manufacturers in the world, with an extensive portfolio of more than 12,000 patents in LED and driver technology. Working with an innovative leader like Seoul gives customers leading-edge technology, along with security against IP litigation.

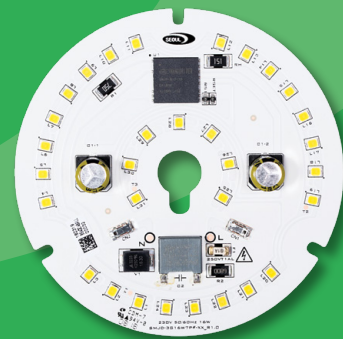

# World Leading Light Engine Technology

AC lighting modules integrate advanced LED and Acrich driver technology

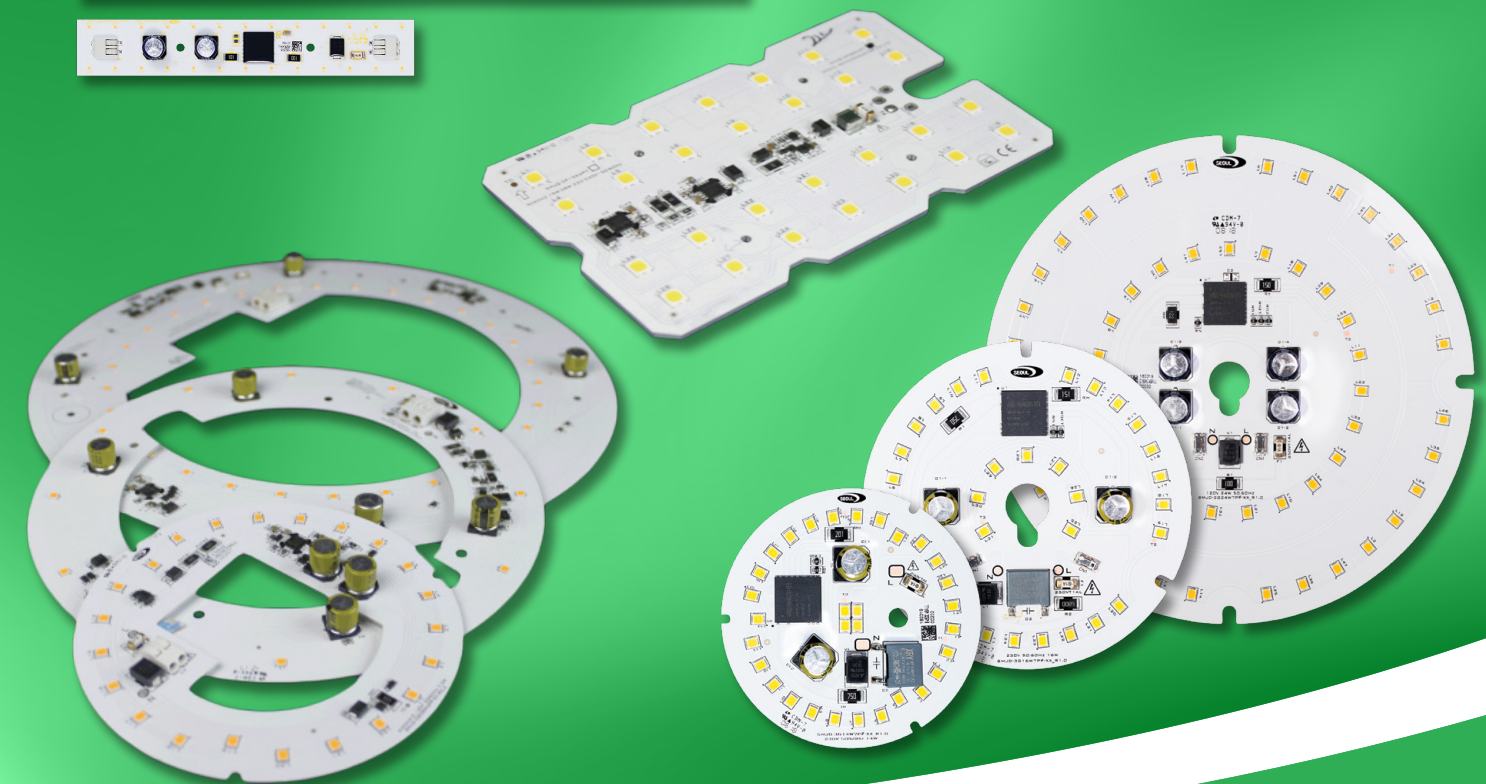

### The Technology Leader

# Acrich LED Driver Technology

Transforming the solid state lighting industry

Seoul Semiconductor's Acrich LED driver technology enables the design of simpler, smaller, more efficient, and less expensive light fixtures. Designed to operate directly from AC power, Acrich drivers eliminate bulky, inefficient transformers and reduce the complexity and size of LED light fixtures.

### Acrich LED drivers deliver

- Simpler and more efficient fixture circuitry
- Smaller light fixture designs
- Superior flicker performance/Title 24 compliant
- Demonstrated light engine efficacy of >150lm/W
- Compatibility with LE/TE and analog dimming

Acrich Multi Junction Transistor technology delivers high performance at lower cost.

Seoul Semiconductor's patented Multi Junction Transistor (MJT) technology enables multiple LEDs to be fabricated on a single die, resulting in higher voltage LEDs without the cost and complexity of multiple dies and wire bonds. High voltage LEDs deliver lower cost, higher reliability and simplified circuit topology.

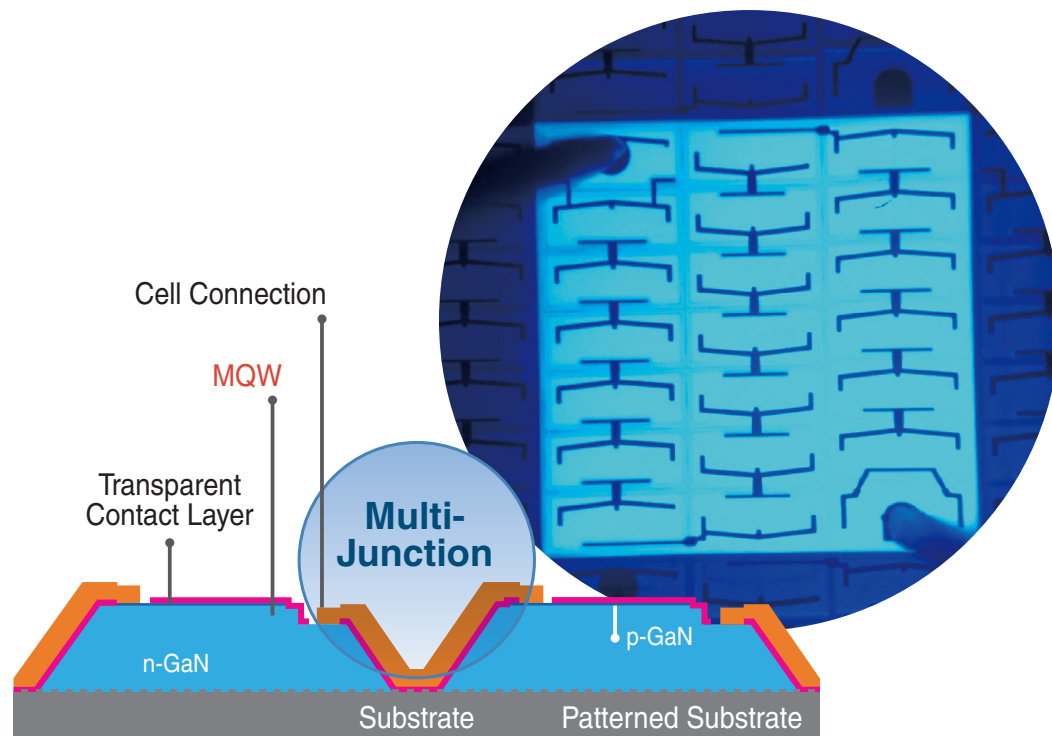

Acrich AC LED Technology Delivers Cost-Effective Light Engine Designs

Seoul Semiconductor's Acrich modules, powered by the NanoDriver Series, the world's smallest 24W LED driver, are smaller, less expensive, and higher performance than modules built with conventional LED technology.

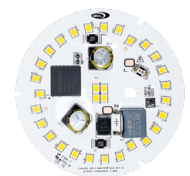
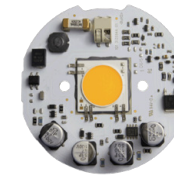

Brand X	NanoDriver Series
78mm	70mm
62 components	9 components
103lm/W	108lm/W
1.5mm creepage	6mm creepage
Non-dimmable	Phase-cut dimmable
	Room to add wireless controller or other components

### Traditional LED Driver

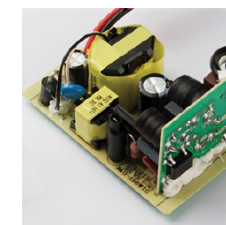
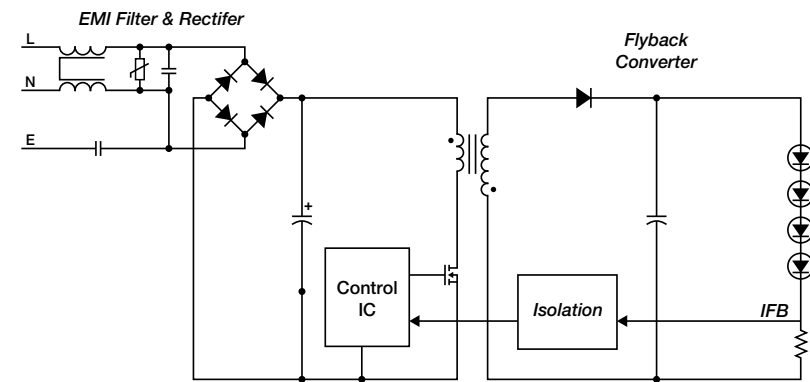

### ACRICH LED Driver

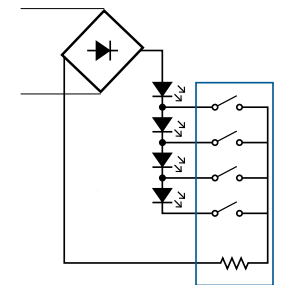

## AC LED Technology: Myth vs. Reality

Separating the myths from the reality of Acrich AC LED technology:

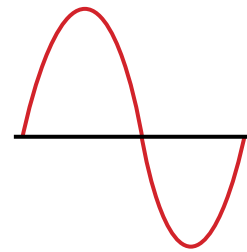

Myth	Reality
AC technology is low efficacy	Seoul Semiconductor's Acrich AC LEDs and drivers have demonstrated efficacy >150lm/W
AC technology has high flicker	Seoul Semiconductor's Acrich AC LEDs and drivers deliver <10% flicker and comply with Title 24 requirements
AC technology is not compatible with dimmers	Seoul Semiconductor's Acrich AC drivers are fully compatible with leading edge and trailing edge dimmers
AC technology has low power factor	Seoul Semiconductor's Acrich AC drivers have a proven power factor >0.9
AC technology is susceptible to surge failures	Seoul Semiconductor's Acrich AC technology exceeds typical industry surge specifications, with modules that withstand 4kV combination wave lightning strikes

For more information about Seoul Semiconductor AC technology, visit: [www.seoulsemicon.com/en/product/Modules](http://www.seoulsemicon.com/en/product/Modules)

## WICOP Package-less LED Technology

### Delivers Uniform Illumination

Seoul Semiconductor's revolutionary WICOP Series package-less LEDs represent a two-generation advance in high power LED technology that enables radically smaller, lighter, and less expensive luminaire designs that feature uniform illumination.

#### WICOP Series LEDs deliver:

- Best-in-class color over angle (COA) performance
- Uniform illumination pattern
- 20% higher light output
- 30–50% systems level savings
- Superior thermal characteristics

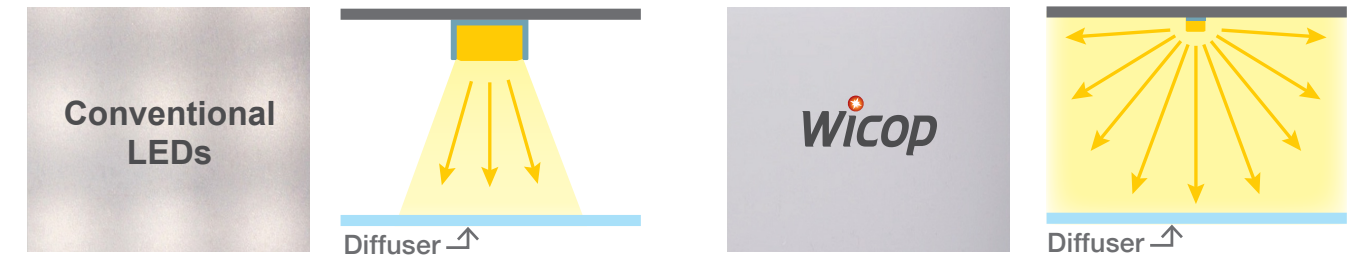

Illumination pattern produces uniform light.

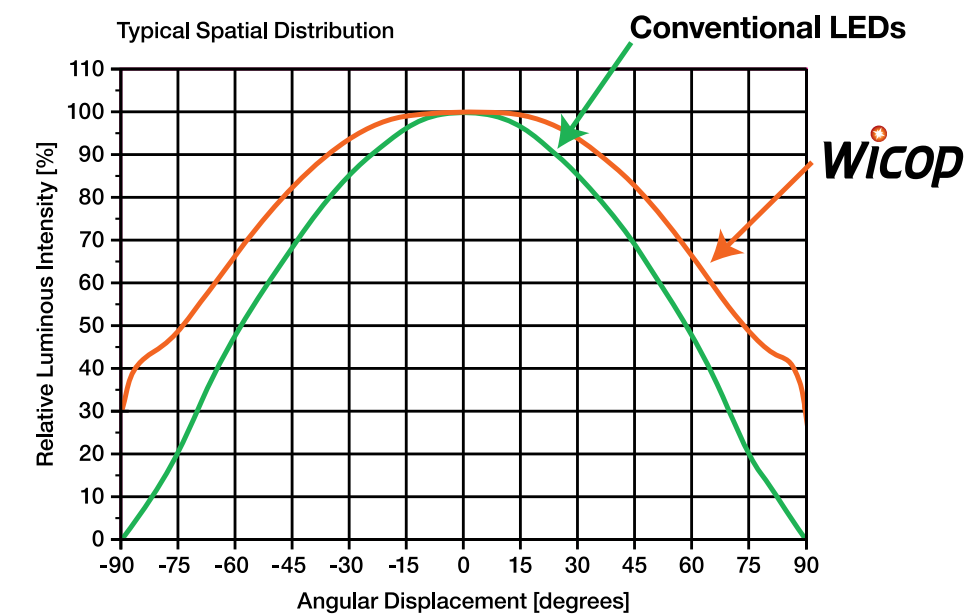

# AC Lighting Modules

## AC Round Modules Provide Complete Lighting Solutions

Part Number	Flux Range (lm)	Diameter (mm)	LES (mm)	120VAC	230VAC	Low Flicker	Dimmable
 SMJE-2V04W4PE-3K	290-380	33	20	Y	N	N	N
SMJE-3V04W4PD-3K				N	Y		
 SMJE-2D08W4PE-3K	670-830	46	34	Y	N	N	Y
SMJE-3D08W4PD-3K				N	Y		
 SMJE-2D12W4PE-3K	910-1130	46	34	Y	N	N	Y
SMJE-3D12W4PD-3K				N	Y		
 SMJD-2G14W7PP-3K	1080-1320	78	64	Y	N	Y	Y
SMJD-3G14W7PO-3K				N	Y		
 SMJD-2G16W7WI-3K	1000-1050	100	85	Y	N	Y	Y

For more information about Seoul Semiconductor AC technology, visit: [www.seoulsemicon.com/en/product/Modules](http://www.seoulsemicon.com/en/product/Modules)

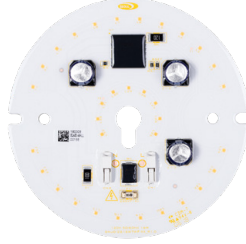
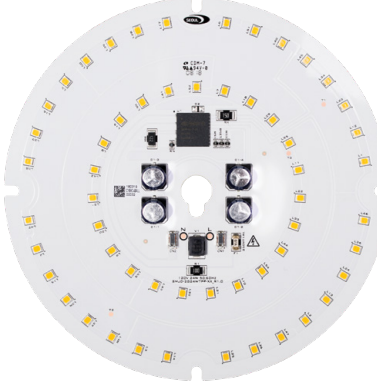
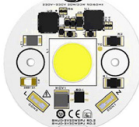
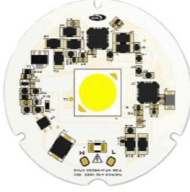
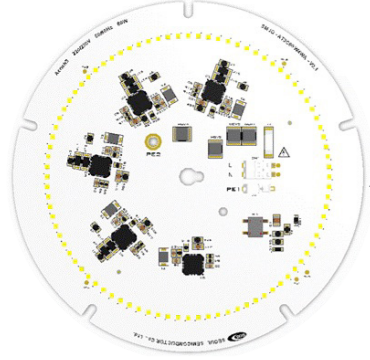
 SMJD-2G16W7PP-3K	1450-1760	100	85	Y	N	Y	Y
SMJD-3G16W7PO-3K				N	Y		
 SMJD-2G24W7PP-3K	2160-2640	160	132	Y	N	Y	Y
SMJD-3G24W7PO-3K				N	Y		
 SMJD-3V30W2PJ-3K	2700-3000	57	14	N	Y	N	N
 SMJD-3D30W4P-3K	2460-3050	78	14	N	Y	N	Y
 SMJQ-2C80W4WA-5K	11000	145	125	Y	N	N	N
SMJQ-3C80W4WA-5K				N	Y		

For more information about Seoul Semiconductor AC technology, visit: [www.seoulsemicon.com/en/product/Modules](http://www.seoulsemicon.com/en/product/Modules)

## AC Rectangular & Linear Modules Provide Complete Lighting Solutions

### AC Residential Rectangular Modules

Part Number	Flux Range (lm)	Length (mm)	Width (mm)	120VAC	230VAC	Low Flicker	Dimmable
 SMJD-2G32W7W-3K	2400-2700	180	180	Y	N	Y	Y
 SMJQ-3C30W4P-5K	2800-3000	120	110	N	Y	N	N
 SMJQ-3C50W4P-5K	4500-4800	120	110	N	Y	N	N
 SMJQ-3C80W4W-5K	8000	150	120	N	Y	N	N

For more information about Seoul Semiconductor AC technology, visit: [www.seoulsemicon.com/en/product/Modules](http://www.seoulsemicon.com/en/product/Modules)

### AC Residential Linear Modules

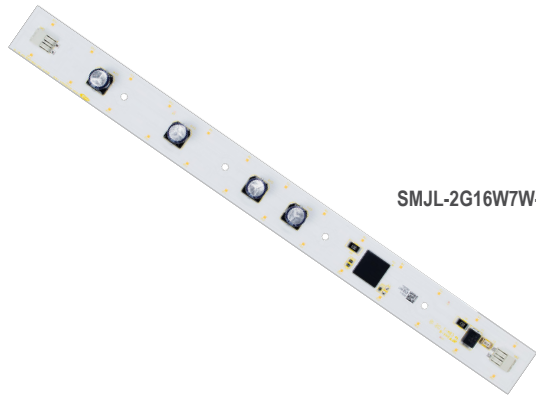
Part Number	Flux Range (lm)	Length (mm)	Width (mm)	120VAC	230VAC	Low Flicker	Dimmable
 SMJL-2G08W7W-3k	700	152.4	25.4	Y	N	Y	Y
 SMJL-2G16W7W-3k	1200	304.8	25.4	Y	N	Y	Y
 SMJL-2G24W7W-3k	2000	457.2	25.4	Y	N	Y	Y

For more information about Seoul Semiconductor AC technology, visit: [www.seoulsemicon.com/en/product/Modules](http://www.seoulsemicon.com/en/product/Modules)

# Custom AC Module Design

Seoul Semiconductor Offers Custom AC Module Design Services to Meet Specific Customer Requirements

Seoul Semiconductor operates several regional design centers – in Korea, China, Japan, USA and Europe – to assist customers in designing and developing custom AC modules and light engines to meet their specifications. With application and design engineering expertise in LEDs, drivers, optics and thermal management, the Seoul Semiconductor team helps customers build best-in-class light fixtures that meet EMC and international regulatory safety standards.

### Custom AC module design capabilities

- DALI and wireless control systems
- Comprehensive dimming options
- IP rating options
- Color tuning
- Custom optics
- Thermal management

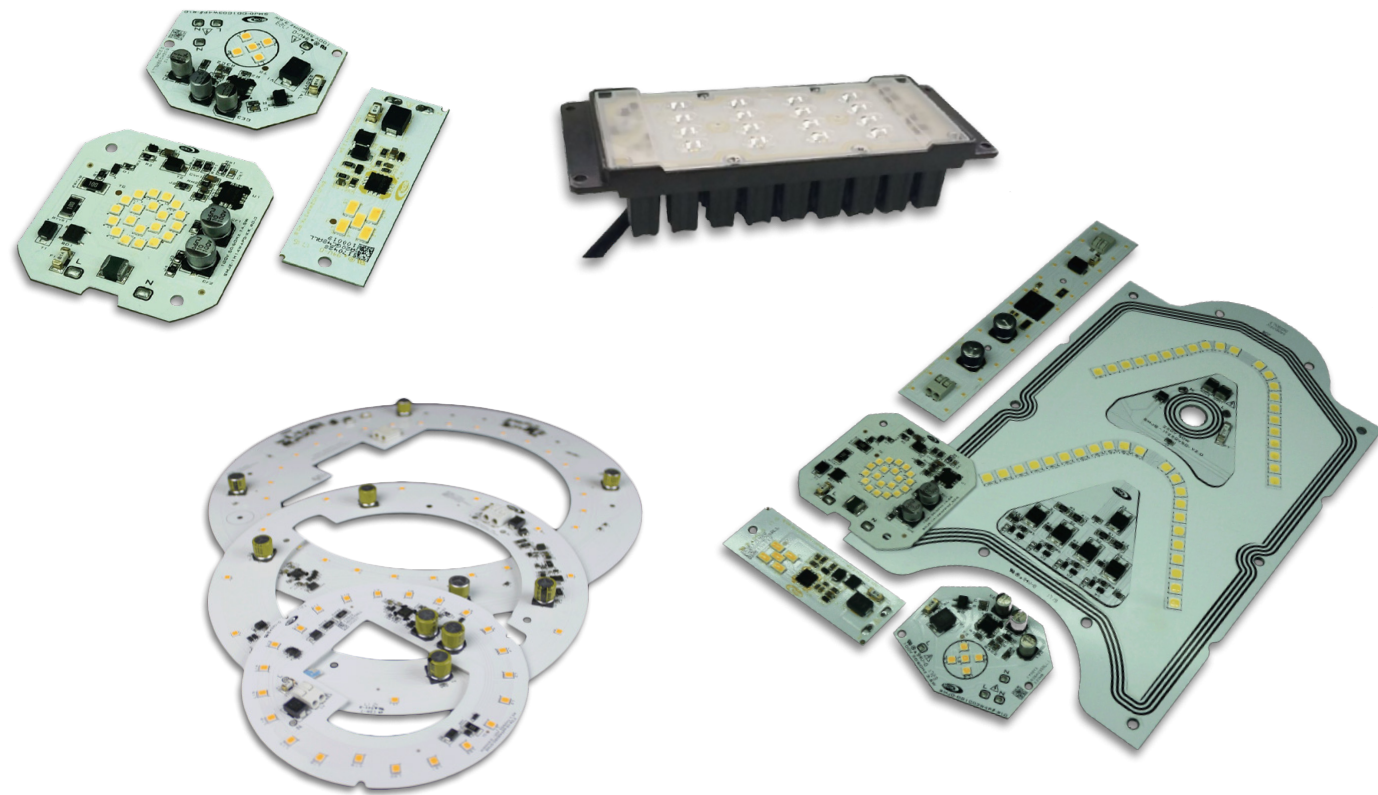

### Seoul Semiconductor AC Module Design Centers

Korea | China | Japan | North America | Europe