

BMA222E

Digital, triaxial acceleration sensor

Bosch Sensortec



BOSCH
Invented for life

General Description

The BMA222E is an advanced, ultra-small, triaxial, low-g acceleration sensor with digital interfaces, aiming for low-power consumer electronics applications. Featuring 8 bit digital resolution, the BMA222E allows low-noise measurement of accelerations in 3 perpendicular axes and thus senses tilt, motion, shock and vibration in cellular phones, handhelds, computer peripherals, man-machine interfaces, virtual reality features and game controllers.

BMA222E target applications

- ▶ Display profile switching (portrait/landscape, face-up/face-down switching)
- ▶ Flat detection
- ▶ Tap / double tap sensing
- ▶ Menu scrolling
- ▶ Gaming
- ▶ Advanced power management for mobile devices
- ▶ Shock and free-fall detection
- ▶ Step-counting
- ▶ Tilt compensation for electronic compass

Sensor features

With its ultra-small footprint of only 2 mm x 2 mm the BMA222E is unique in the class of low-noise, 8 bit digital acceleration sensors. On top, the BMA222E integrates a multitude of features that facilitate its use especially in the area of motion detection applications, such as device orientation detection, gaming, HMI and menu browser control. Featuring a full operation current consumption of only 130 μA the BMA222E is ideally suited for mobile consumer electronic devices. In low-power mode operation the current consumption can be even further reduced by more than one order of magnitude. The BMA222E is highly configurable in order to give the designer full flexibility when integrating the sensor into the system.

BMA222E	Technical data
Digital resolution	8bit
Resolution (in $\pm 2\text{g}$ range)	15.6 mg
Measurement ranges (programmable)	$\pm 2\text{g}$, $\pm 4\text{g}$, $\pm 8\text{g}$, $\pm 16\text{g}$
Sensitivity (calibrated)	$\pm 2\text{g}$: 64 LSB/g $\pm 4\text{g}$: 32 LSB/g $\pm 8\text{g}$: 16 LSB/g $\pm 16\text{g}$: 8 LSB/g
Zero-g offset (typ., over life-time)	$\pm 100\text{mg}$
Noise density (typ.)	600 $\mu\text{g}/\sqrt{\text{Hz}}$
Bandwidths (programmable)	1000 Hz ... 8 Hz
Digital inputs/outputs	SPI & I ² C, 2x digital interrupt pins
Supply voltage (V_{DD})	1.62 ... 3.6V
I/O supply voltage (V_{DDIO})	1.2 ... 3.6V
Temperature range	-40 ... +85°C
Current consumption	
▶ full operation	130 μA (@ 2kHz data rate)
▶ low-power mode	6.5 μA (@ 40Hz data rate)
FIFO data buffer	32 sample depth (for each axis)
LGA package	2 x 2 x 0.95 mm ³
Shock resistance	10,000g x 200 μs

Sensor operation

The BMA222E supports two modes of operation:

1) Standard data polling mode: Acceleration data is directly read-out via the sensor's digital interface and computed by a system $\mu\text{Controller}$, application processor or a base-band processor.

2) Interrupt engine mode: Acceleration data is computed already within the BMA222E by the integrated, programmable interrupt engine.

Depending on the programmable settings the integrated interrupt engine of the BMA222E signals the occurrence of certain events via the sensors` two interrupt pins. The corresponding registers of the BMA222E can easily be set and read-out via the digital sensor interface.

The BMA222E features I²C and SPI (3-wire/4-wire) digital, serial interfaces. Sensor parameters, like g-ranges or low-pass filter settings, and also all interrupt engine settings can be easily programmed via the digital interfaces.

Integrated interrupt engine

One of the key elements of the BMA222E is the enhanced intelligent interrupt engine that gives the hard and software designer full control. Various motion detection scenarios can be identified by the BMA222E and signaled to the system via two interrupt pins. The interrupt sources can be freely mapped to either of the two interrupt pins. The following motion detection use case scenarios are supported by the BMA222E interrupt engine:

- ▶ Data-ready (e.g. for processor synchronization)
- ▶ Any-motion (slope) detection (e.g. for wake-up)
- ▶ Tap sensing (e.g. for tap-sensitive UI control)
- ▶ Orientation change recognition (e.g. for portrait/landscape switching)
- ▶ Flat detection (e.g. for position sensitive switching)
- ▶ Low-g / high-g detection (e.g. for shock and free-fall detection)
- ▶ No-motion (e.g. for power saving)

Interrupt parameters (e.g. switching angles and hysteresis settings for orientation change) can be configured by the designer and thus perfectly support the integration of the BMA222E into the user`s system environment.

System compatibility

The BMA222E has been designed for best possible fit into modern mobile consumer electronics devices.

Besides the ultra-small footprint and lowest power consumption, the BMA222E has very wide ranges for V_{DD} and V_{DDIO} supply voltages. The BMA222E also includes a FIFO buffer with 32 samples depth for each acceleration axis. An integrated self-test feature facilitates overall system reliability.

Pin configuration (top view)

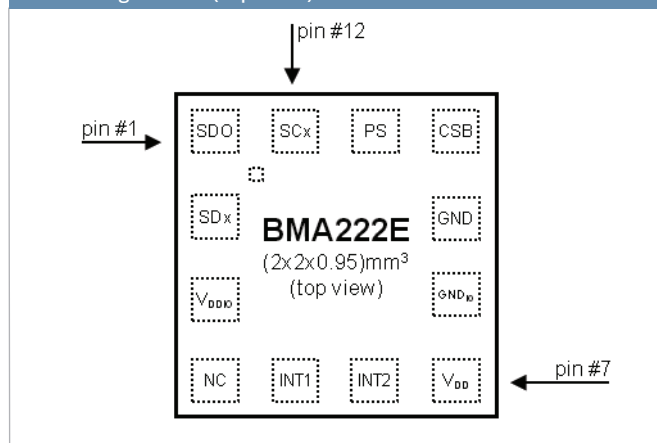

Pin	Name	Description
1	SDO	SPI: serial data output in SPI -wire mode I ² C: I ² C address select
2	SDx	SPI: SDI serial data input in SPI 4-wire mode SPI: SDA serial data I/O in SPI 3-wire mode I ² C: SDA serial data line
3	V _{DDIO}	Voltage supply for I/Os
4	NC	Not connected
5	INT1	Interrupt output #1
6	INT2	Interrupt output #2
7	V _{DD}	Voltage supply
8	GND _{IO}	Ground for I/O
9	GND	Ground
10	CSB	Chip select for SPI
11	PS	Protocol select: SPI: GND I ² C: V _{DDIO}
12	SCx	SCK: SPI clock SCL: I ² C clock

Headquarters Bosch Sensortec GmbH

Gerhard-Kindler-Strasse 8
72770 Reutlingen · Germany
Telephone +49 7121 3535 900
Fax +49 7121 3535 909
contact@bosch-sensortec.com
www.bosch-sensortec.com